

THIS DRAWING IS UNPUBLISHED. RELEASED FOR PUBLICATION  
 © COPYRIGHT - By - ALL RIGHTS RESERVED.

LOC	DIST	REVISIONS					
AF	50	P	LTR	DESCRIPTION	DATE	DWN	APVD
		B		REVISED PER ECR-13-001204	03JUL13	KH	PD

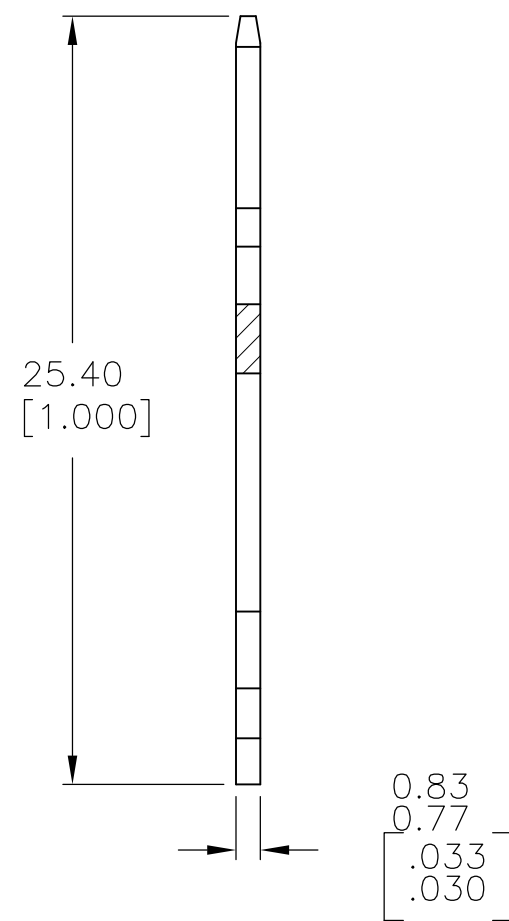

- 1 CONTINUOUS STRIP ON REELS
- 2 FEED IS 8.89±0.076 [.350±.003].
- △3 0.00381 [.000150] MIN TIN OVER  
0.00127 [.000050] MIN NICKEL.
- △4 REELED WITH INTERLEAVING PAPER.
- △5 PRELIMINARY - NOT FOR PRODUCTION

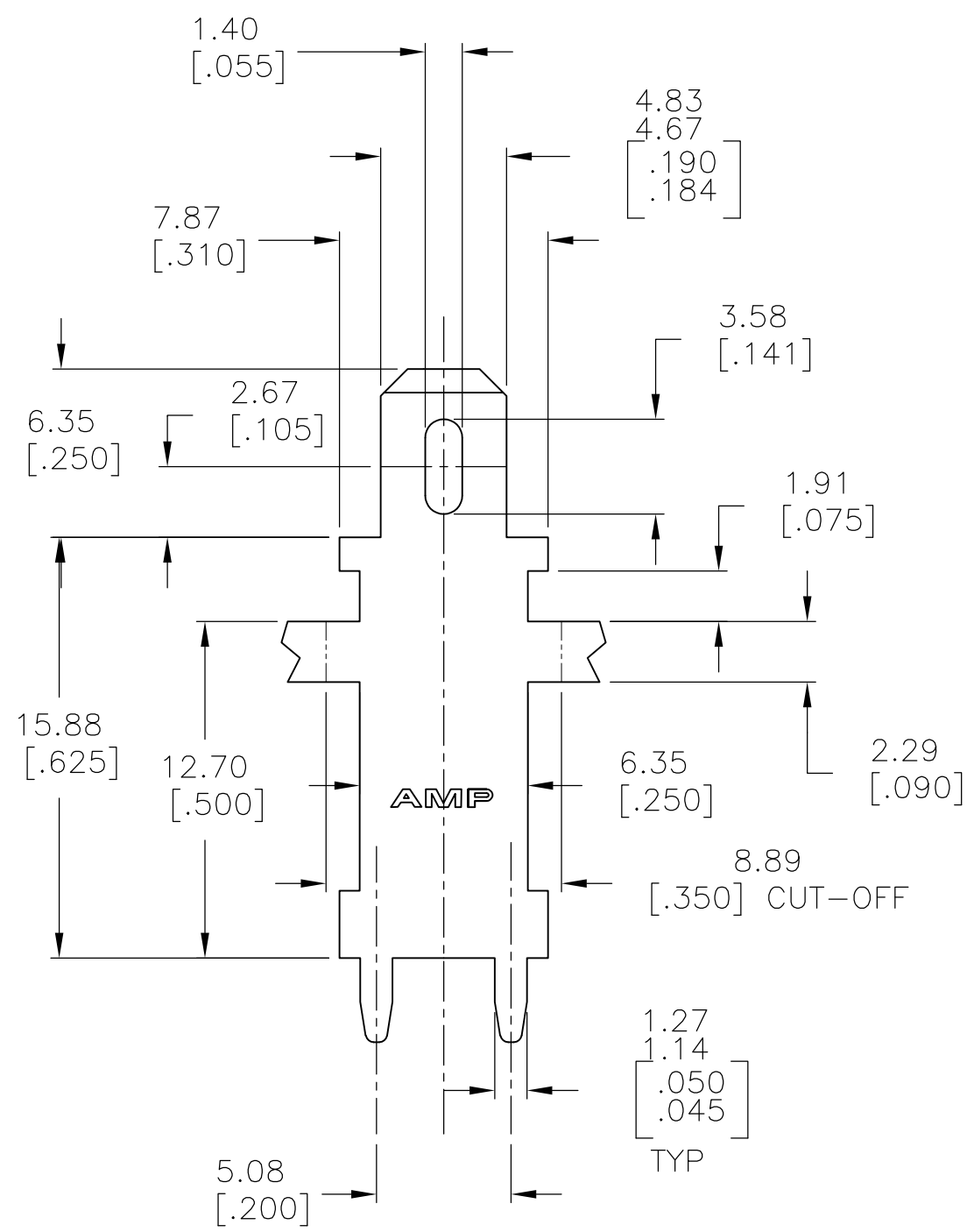
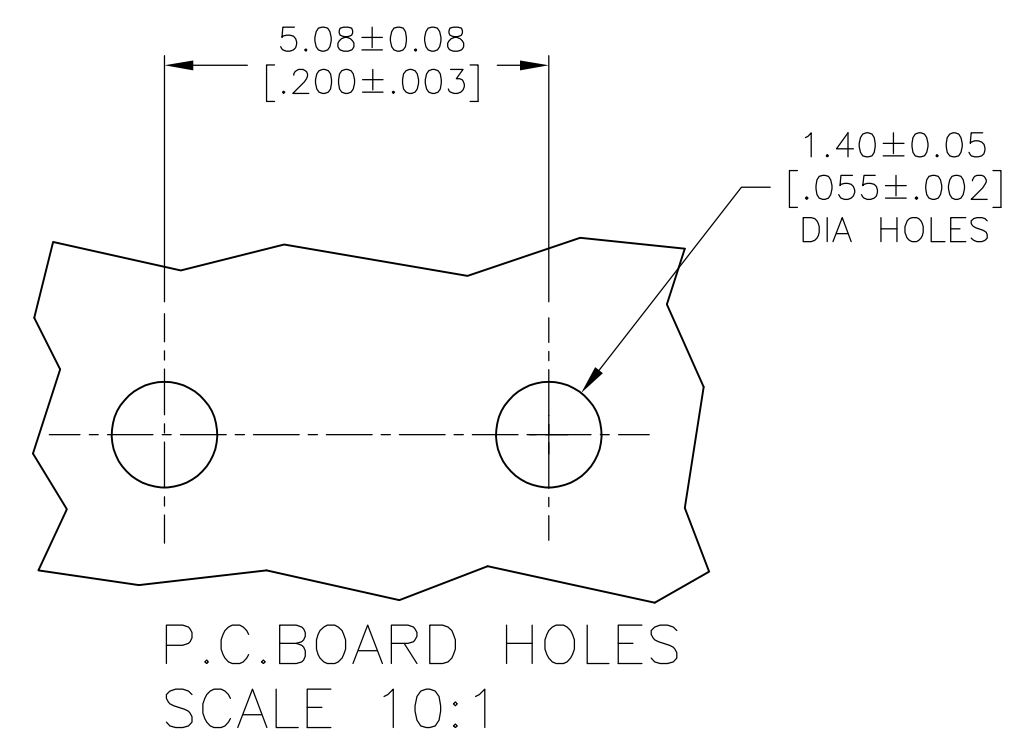

△4	BRASS	△5	1742664-2
	BRASS		1742664-1
	MATERIAL		PART NO.

THIS DRAWING IS A CONTROLLED DOCUMENT.		DWN	JR RUTH	28NOV07	<b>STE</b> TE Connectivity			
DIMENSIONS: mm [INCHES]		CHK	J KNOLL	28NOV07				
TOLERANCES UNLESS OTHERWISE SPECIFIED:		APVD	J KNOLL	28NOV07	NAME			
0 PLC ± -		PRODUCT SPEC		TAB, FASTON, P.C. BOARD, 4.75 [.187] SERIES				
1 PLC ± -		APPLICATION SPEC		114-2115	SIZE	CAGE CODE	DRAWING NO	RESTRICTED TO
2 PLC ± 0.25 [.010]		MATERIAL		SEE TABLE	A3	00779	C-1742664	-
3 PLC ± -		FINISH		△3	CUSTOMER DRAWING		SCALE	4:1
4 PLC ± -					SHEET		1 OF 1	REV
ANGLES ± -								B